

SECTION 18
References and
case stories

BROEN
BALLOMAX®

Designed to last

Sustainable and energy efficient Danish district heating solution

BROEN Ballomax® delivers a proven solution to the energy challenge.

Aabybro district heating plant (Denmark).



District heating plays an important part in Danish energy supply and is part of a balanced national energy plan to reduce carbon emissions and the use of finite resources in Denmark.

A small town in the Northern part of Denmark sets a high standard for efficient district heating and presents a sustainable and efficient solution distributing clean and efficient energy to around 2,000 private households in the town of Aabybro.

In 1986 the plant Aabybro Fjernvarme (Aabybro District Heating Plant) switched from oil to wood chips based heating and in April 2016 a brand new energy efficient plant was inaugurated. The plant is established as a co-operative, where the customers are also the owners of the plant. The significant design of the new plant included functionality and process flow as key design parameters.

The building follows the shape of the main boiler – technical dimensions have determined the architecture, which adds a significant profile to the otherwise surrounding flat landscape.

Dänische Fernwärme und die dänische Genossenschaftsbewegung

The concept of district heating was invented in Denmark as part of the cooperative movement. The members were all owners and shared the economic stress of producing goods or buying capital investments and then divided the financial surplus. This created synergies beyond the sum of individual investments.

During the 1980s Danish energy operators started connecting the individual networks. A shared transmission grid connected all the local district heating networks to share excess capacity and level out production peaks.

Kathrine – an energy efficient lady getting the job done.

Aabybro Fjernvarme transforms wood chips to energy. The chips come from national forestry and local farmers thinning the vegetation around their fields.

The main component in the heat station in Aabybro is the boiler called Kathrine – named after a famous Danish TV character. She is a solid, sturdy and practical hard working character, who gets the job done.

Main boiler – Kathrine and close-up of wooden chips During the combustion the temperature in Kathrine drops from more than 1,000°C in the combustion chamber to 180°C and as the final step a condensation process is added bringing down the temperature to 38°C.

The heat from the combustion process is used to heat up the water for the town of Aabybro. As yet another gain some of the ashes produced from the combustion are re-circulated and sold as an ingredient for fertilizer materials. Kathrine processes chips with a humidity between 35% - 55%. With a nominal capacity of 8.4 MW she has plenty of power and volume to get the job done.

The boiler was installed by the company Weiss - a Danish plant construction company, who delivered a complete key solution for Aabybro District Heating Plant - also including pumps, valves and pipes.

Weiss is a recognized specialist in district heating plant constructions – and very well familiar with the valves from BROEN. John Myrup from Weiss A/S

Main boiler – Kathrine and close-up of wooden chips



says: “Many customers ask for fully welded ball valves for shut off applications instead of butterfly valves, because the ball valves are more reliable. Over the years Weiss has built up a good experience using BROENS ball valves for district heating plants and it is a brand that customers trust – the valves are long lasting and operate with no problems. BROEN Ballomax® still proves itself among the most efficient and reliable district heating valves on the market today”.

BROEN Ballomax® - designed to last.

The plates of a large heat exchanger is where the heat from Kathrine is transferred to the outside circuit distributing heated water for the town and the connected local industrial plants. In a closed loop the water circulates back to the plant, where it is again heated up in the heat exchanger, distributed to the households and then the re-circulation continues – driven by the pump station of the heating plant. BROEN Ballomax® ball valves controlling the flow of district heating water

In the pump station the BROEN Ballomax® ball valves play an important role as reliable and efficient shut off valves for controlling the flow through the different pipelines, where a valuable stream of hot water supplies the town of Aabybro with hot water. Giant amounts of water push through the components every day and long lasting reliability is required for any opening and closing mechanism. With temperatures around 165°C shutting the valves tightly and efficiently on and off in order to direct the flow efficiently is very important and no downtime or leakages are accepted.

All BROEN Ballomax® ball valves are tested according to PED module H to secure they will perform satisfactorily over their entire lifetime. Each and every component has been carefully designed. The spindle of a BROEN Ballomax® valve is mounted from the inside and cannot be ejected and there is minimal maintenance of a BROEN Ballomax valve body as no parts require replacement or lubrication. Only a yearly activation is recommended to secure that the ball does not get stuck in the retainer – this means a minimum of work for the customer.

Inside the valve the control of the media is provided by a stainless steel ball closing against selflubricating seats to secure superior sealing and low friction – which again means that closing and opening require relatively little torque and small dimensioning of gears and activation. The floating ball is self-centering and the seats are backed up with springs and retainers to ensure constant contact pressure between the ball and the seat. BROEN Ballomax® allows a maximal handle turn of 90°.

BROEN – complete offerings for district heating.

BROEN Ballomax® valves are used in the distribution system towards the town and Plant Manager at Aabybro Fjernvarme, Torben Stenbroen explains: “I want to have the same quality of valves in the distribution to the town, as I have in the plant and here quality was a deciding parameter in the construction phase. In general we aim for one supplier- and service interface for all valves.

With BROEN Ballomax® we hope to get long lasting quality and reliability in our distribution system too”.

For the town of Aabybro BROEN has supplied valves for installation both above and below ground, isolated flexible main stop valves for house inlets as well as well-valves - combining two valves in one well.



BROEN Ballomax® ball valves controlling the flow of district heating water

BROEN can supply a comprehensive range of valves for district heating distribution grids and plants: installation above or below ground, floating or trunnion mounted balls, valves for steam, installation in wells or twin valves, gears, actuation and extensions.

For further information and relevant contact information please see: www.broen.com

BROEN Ballomax® – Designed to Last

Fully welded steel ball valve
 Heating | Cooling | Steam
 Temperatures up to 200°C
 DN10 – DN500
 PN16 | PN 25 | PN 40
 Full bore | Reduced bore

Climate-friendly combined heat and power station in Elsinore.

BROEN Ballomax® with double bearing valve ball securing effective shut-off and correct flow.

Helsingør Forsyning (Denmark).



Kronborg Castle – effective control in the 1420s

From time immemorial the Kronborg Fortress located just outside Elsinore controlled the ships passing through the Sound and protected the infrastructure and values of the Danish kingdom to ensure that no enemy ships passed through the Sound and that correct tax was paid for passage.

Identically the heating supply in Elsinore in 2017 is a central element in today's infrastructure and must operate optimally to ensure that the large quantities of hot water circulated daily are used, where the heat is required – and not lost en route.

Green transition and renovation

Forsyning Helsingør, the local public utilities company in Elsinore, is planning to renovate district heating and make it future-proof. A reliable solution at competitive prices is requested, a solution also supporting the green transition from 2019 – this is both a local target and a national issue. In order to meet this target, the power station is in the process of replacing natural gas as fuel by sustainable wooden chips – and commence a future that is no longer based on fossil fuels.

Forsyning Helsingør intends to be one of Denmark's leading public utilities companies promoting a well-functioning and eco-conscious local

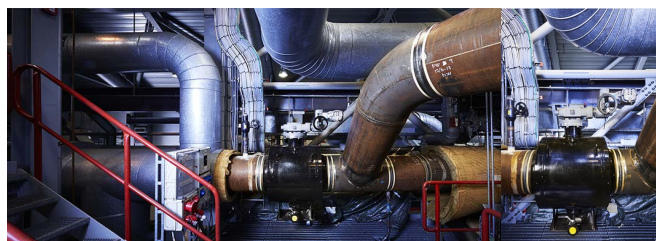

BROEN Ballomax® DN50 – Double bearing valve ball with Double Block and Bleed – DBB – outlet under the valve body

society and supplying electricity, water and heating as well as making sure that waste and waste water are handled correctly.

Forsyning Helsingør – the peak load station remains an asset.

Today the heat and power station primarily produces electricity and as a secondary, run-off product district heating can be circulated in the district heating system of the town. With an output of 55 MW the existing heat and power station is to remain active as a reliable back-up and peak load station. The boiler of the station is fired by natural gas and produces steam to a steam turbine that in turn produces power.

The peak load station will be put into operation if the price of electricity is high and the price of natural gas low – and if electricity prices are favorable and it is operationally sound, heat is also produced to a storage tank holding 16,000m³ – approx. 700 MW. The peak load station is renovated to effectively secure a correct flow, effective shut-off and to optimize the synergy with the new wooden chip plant.

Consequently, in the spring of 2017 Forsyning Helsingør had four new BROEN Ballomax® DN500 Trunnion valves with DBB outlet valves welded into the existing power station (all four valves are 150°C / PN25).

Two BROEN Ballomax® valves function as main shut-off valves between the new biomass plant and the combined heat and power station. Two other BROEN Ballomax® valves with AUMA gear function as bypass valves, that can direct the supply pipe water from the biomass plant into the steam boiler for further heating, if the temperature is not sufficiently high, before it is circulated to the users. With a maximum flow capacity of 2,400m³/h, temperatures of up to 120°C and a pressure of up to 25 bar, it is important that the valves function correctly.

Forsyning Helsingør has chosen to renovate the combined heat and power station with a sustainable fuel in the form of wooden chips. The existing station will be upgraded to function as a reliable peak load station and the components must also here function safely and optimally. Therefore BROEN Ballomax® valves have been chosen with functionalities providing additional reliability as a non-planned shut-down would be a disaster. Great importance has been attached to buying from a proven supplier, that backs up his product – and that will also be around tomorrow.

BROEN Ballomax® Trunnion with Double Block and Bleed

The new valves welded into the station have a special job to do and are so-called Trunnion valves – i.e. double bearing valves which means that the ball is anchored both at the top and at the bottom. This reduces friction and torque considerably, when the valve is activated. Valves fitted with a relief valve - popularly called a "tell-tale valve" - ensure, that the chamber between the ball and the body can be completely emptied, so that it is possible to ascertain, if the valve closes 100% tightly – hence the name Double Block and Bleed.



BROEN Ballomax® DN50 – Double bearing valve ball with Double Block and Bleed – DBB – outlet under the valve body

Green energy solutions to district heating construction projects.

BROEN Ballomax® valves – active players in the transition to renewable energy.

Hobro District Heating Station – a new district heating station with BROEN Ballomax® valves.



Denmark towards 2030 – green energy transition

Denmark towards 2030 – green energy transition According to the Danish Council on Climate Change Denmark's transition towards 2030 requires the proper building bricks to be put together correctly so that the vision of a society with low greenhouse gas emissions is fulfilled. One of Denmark's climatic targets is that 50 per cent of energy consumption in 2030 must be covered by renewable energy – and that is an import milestone with great signalling value in relation to the future vision of a low emission society in 2050.

Green components in Danish construction projects

Right now the Danish district heating sector is going through a transition to meet the requirements of a green and renewable energy production and that in turn imposes requirements as to how production in existing district heating stations is changed most effectively. The heart of the district heating system is a production station that centrally ensures that supply and demand are balanced and adjusted according to Denmark's fluctuating energy consumption - 24/7. The green transition to renewable energy production involves major complex building projects that make

great demands on the construction of the stations and the components chosen.

BROEN A/S in Assens works together with and supplies well proven and thoroughly tested valve solutions and valve technology to energy companies and leading constructors in the entire district heating sector. Reliability and flow characteristics are important to ensure the green transition. The innovative heritage from Danish district heating and BROEN's long-standing experience with the development and manufacture of valves for district heating and cooling make BROEN Ballomax® a key component in district heating stations worldwide.

Tjærborg Industri – a constructor with a proven record For many years BROEN has been working closely together with Tjærborg Industri that supplies complete turnkey contracts to the entire district heating sector – with subsequent service to the stations constructed.

The reliability of the components chosen is therefore of great importance to Tjærborg Industri and downtime has severe consequences –

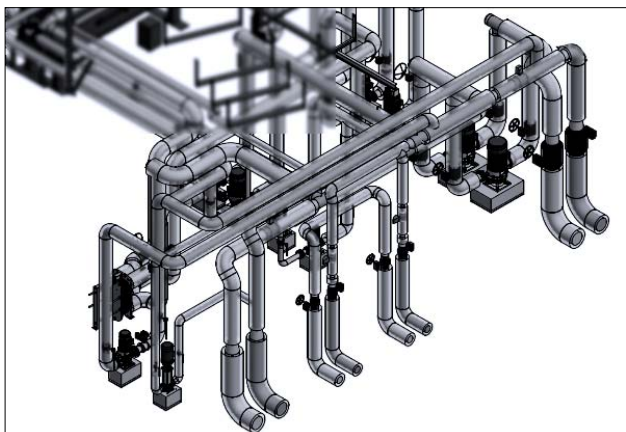
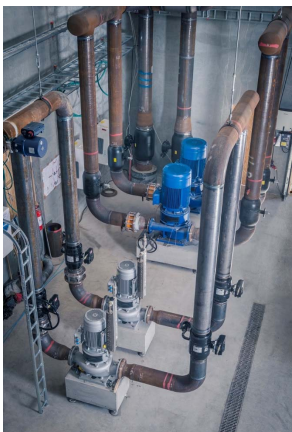

Hobro District Heating Station: Booster station with BROEN Ballomax® valves.

Tjærborg Industri: 3D layout drawing from heating station.

particularly in a changing climate with many cold degree days like Denmark. Tjærborg Industri, today Denmark's leading supplier of complete solutions to the district heating sector, also supplies BROEN valves to many other types of projects in addition to the chip burning district heating stations.

In the spring of 2017 Tjærborg Industri started the construction of a new chip burning station for Hobro District Heating Station – a station with a nominal effect of up to 13 MW. The installation has a budget of approx. 45 million DKK and boiler line 1 is expected to come into operation late October 2017, phase 2 with yet another boiler line will be initiated.

With temperatures of up to 155°C and a pressure of up to 10 bar it is important that all valves installed operate correctly – each time they are activated over the next many years. Tjærborg Industri has chosen BROEN Ballomax® valves from BROEN A/S in Assens as safety, reliability and a supplier of long standing backing his product were of utmost importance.

Trunnion mounted valves are double bearing valves which means that the ball is anchored at the top and at the bottom. That reduces friction and torque considerably when the valve is activated. BROEN Trunnion valves are as standard fitted with a relief valve - popularly called a "tell-tale valve" - that ensures that the chamber between the ball and the body can be completely emptied so that it is possible to ascertain if the valve closes 100% tightly – hence the name Double Block and Bleed. The DBB outlet can be fitted with an additional pipe and ball valve to ease accessibility and operation.

For more information on BROEN and BROEN Ballomax® go to www.broen.com.

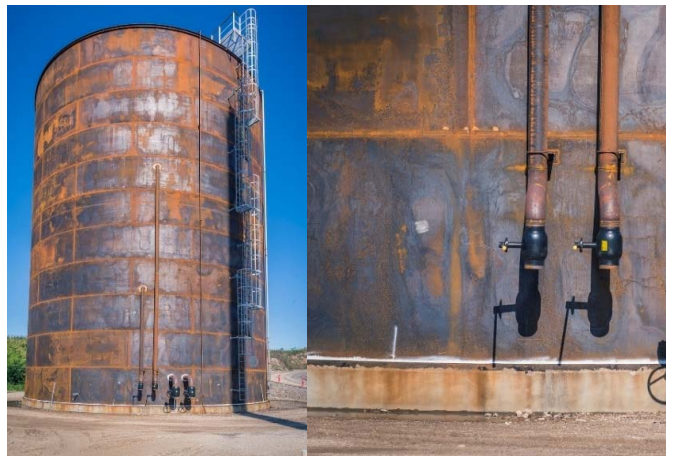

Hobro District Heating Station: BROEN Ballomax® valves DN250-400 – Designed to last.

BROEN Ballomax® DN250 – DN400 valves – Double bearing valve balls with Double Block and Bleed and outlet – during welding at Hobro District Heating Station



