

www.broen.com

BROEN
VALVE TECHNOLOGIES

BROEN BALLOMAX® DN10-50

For district heating and district cooling



BROEN
BALLOMAX®

Designed to last

Climate change is our common challenge

Energy efficiency is one of the greatest challenges of our times and for district energy BROEN delivers ready solutions to meet the globally rising demand for energy efficiency.

Based on the heritage from leading edge innovations in Danish district heating, BROEN BALLOMAX® offers the most comprehensive range of proven ball valves for distribution and transmission of district energy in residential, commercial and industrial applications and is today a key component in district heating and district cooling networks throughout the world.

BROEN A/S is ISO45001, ISO 9001:2015 and ISO 14001:2015 certified.

Our brand is our promise.

ABOUT BROEN

In 1948 Poul Broen established the company BROEN, which was among the pioneers, when district heating took off in Denmark. In 1982 the BROEN BALLOMAX® DN10-50 ball valve for district heating was launched. We strive to develop and improve products, that use nature's resources as efficiently as possible.

In 1993 BROEN was acquired by Aalberts Industries and today we have more than 15,000 colleagues operating from more than 200 locations in more than 30 countries. Aalberts Industries (AALB) is listed at the EuroNext Stock Exchange, NL

VISION AND VALUES

Our vision is simple: Be the best in valve technology. Strong values are the foundation for our business and with the same shared vision they link us together as one company across borders and time zones on 3 continents.



BROEN BALLOMAX® – our response. Next generation valve technology

BROEN BALLOMAX® full bore (DN10-50) was developed to offer a safe, modern and efficient shut-off valve for district heating networks.

The proven range of BROEN BALLOMAX® now offers more solutions than ever.

The valve is tested and subjected to a 100% quality control before leaving the factory and it therefore requires minimal service for the rest of its life.



PED 2014/68/EU - module H
EN 12266-1 and -2

BROEN now introduces the next generation valve technology for district energy

- Energy efficiency – designed to last!
- Compact design
- Optimized full bore valve
- Traceability – individual valve identification
- Patented Danish design – produced in Denmark

Full bore DN10-50 | PN25 | Weld, female or male



Compact design

Stem design

The O-rings can be replaced and spare O-rings come in a special spare part kit with tools.

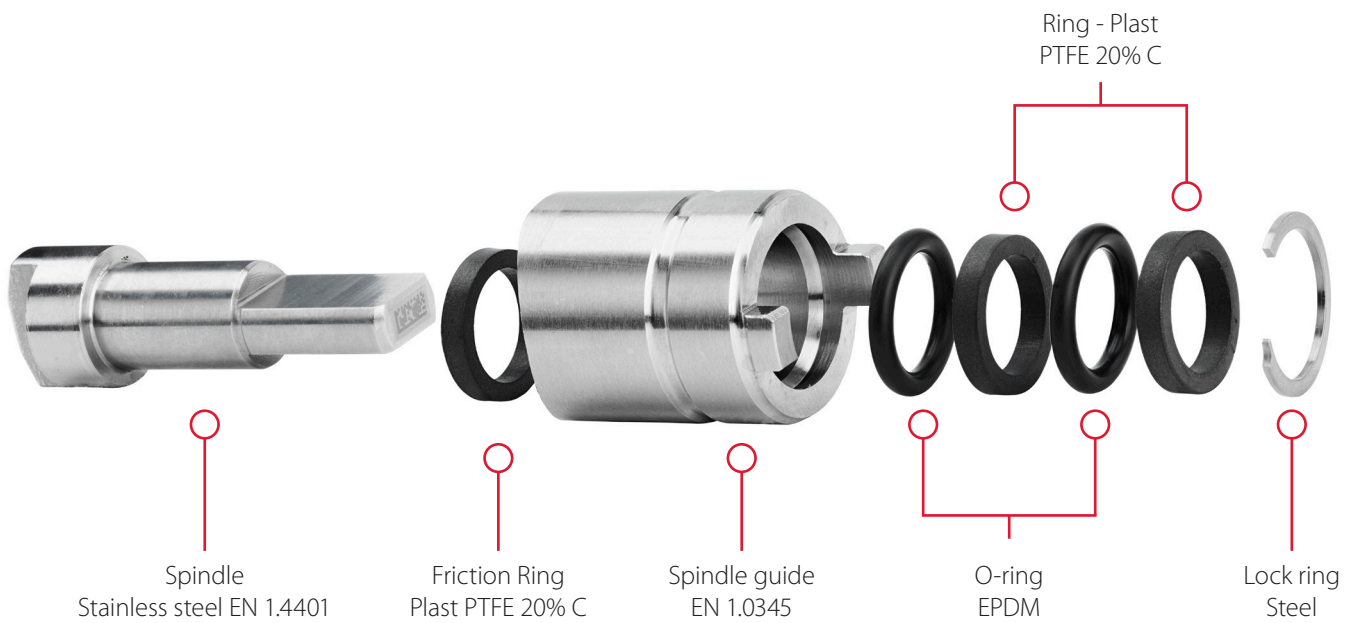

Blow-out proofed stem design

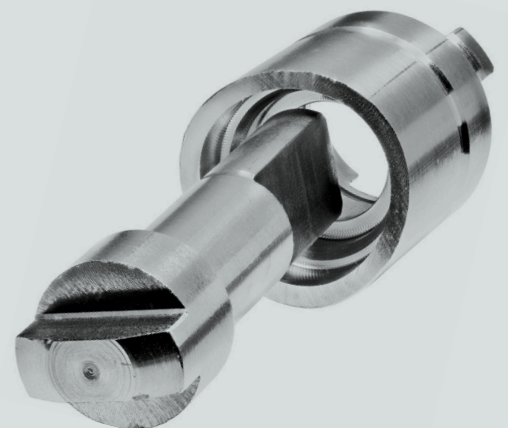
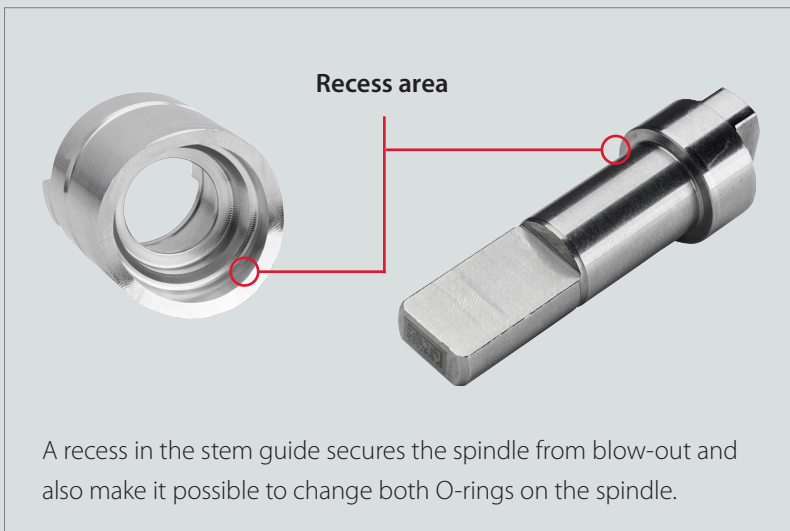

Optimized valve design

Seat design

The new BROEN BALLOMAX® features a new patented spring supported seat design. This new design ensures an optimal tightness and operation of the ball. This contributes to a longer life time with less wear on the sealing material.

The design of the profile of the seat support allows for a certain movement and work as a spring. This means a simple durable design with less components in the sealing area.

The new BROEN BALLOMAX® allows for flow in both directions as there is a spring supported seat on both sides of the ball.

Valve connection overview



Seat design materials



Traceability – individual valve identification

Traceability – Individual valve identification

Each unique valve ID number is linked to a unique data matrix on the top of the spindle. With this we can trace information from our manufacturing process of each individual valve such as quality and process-, test- and distribution data. This information is traceable back to BROEN.

Surface treatment

All BROEN BALLOMAX® valves are powder coated with a laser marking written in the black coating – not penetrating it – hence keeping a full corrosion protection.

Lasermarking

On top of practical installation information, the laser marking on the outside of the valve body includes a unique individual valve ID number enabling us to provide process and manufacturing data to customers.



Patented Danish design – produced in Denmark

Handle

The solid steel handle is manufactured with fibreglass reinforced nylon around it, in order to create a both durable but also comfortable and ergonomic handle, which does not easily transfer heat.

The handle can be removed and mounted in both flow directions without any use of tools. The handle can be supplied with coloured clips to indicate media characteristics.

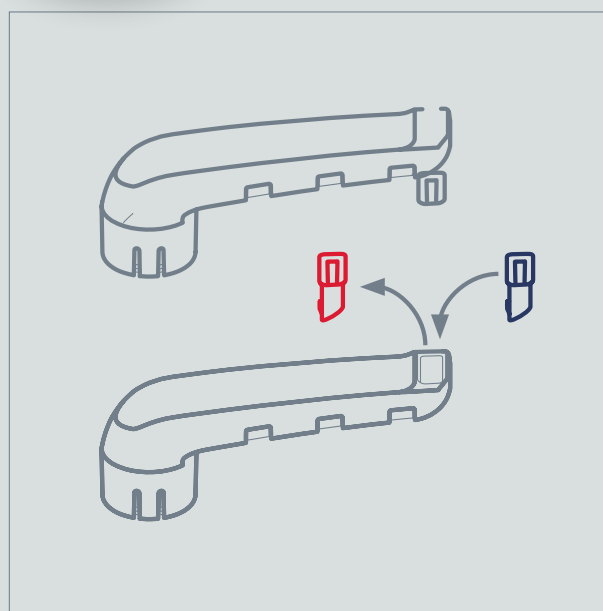
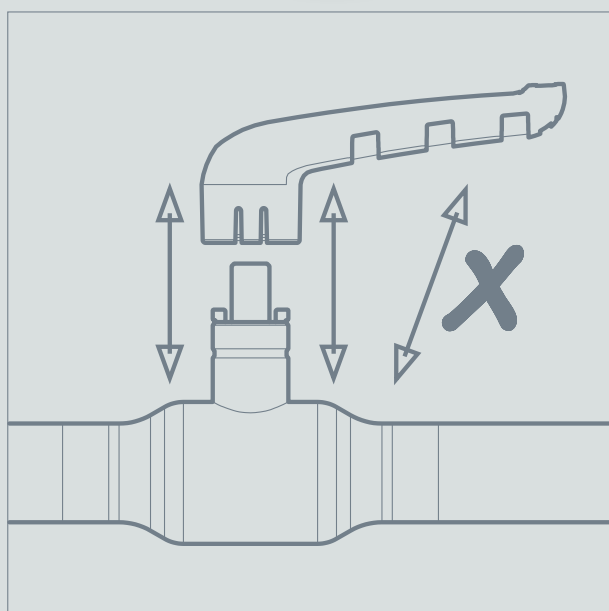
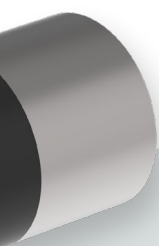

New BROEN BALLOMAX® range

The new addition to the proven line of BROEN BALLOMAX® district heating valves is offered in a range of different variants:

- DN10-50
- Full bore
- PN25
- Weld, female or male

Applications:

- Heating
- Cooling
- Industrial applications

Compact valve design

The compact valve body in one piece offers the best opportunities for insulation in the market – matching requirements in modern efficient district heating systems.

Optimized full bore valve

The high Kvs value secures optimal flow. A full bore construction means a minimum of pressure drop, less noise and less energy consumption.

Energy efficiency – designed to last

The construction requires less torque and actuation to operate, which again means less wear on the sealing material. This construction secures a longer lifetime.

Connection technologies

The valve is available with either weld, male or female connections.

Patented Danish design – produced in Denmark

The patented spring supported seat design secures optimal tightness and operation of the ball due to less torque and actuation required. This converts into less wear on the sealing material and a longer lifetime.

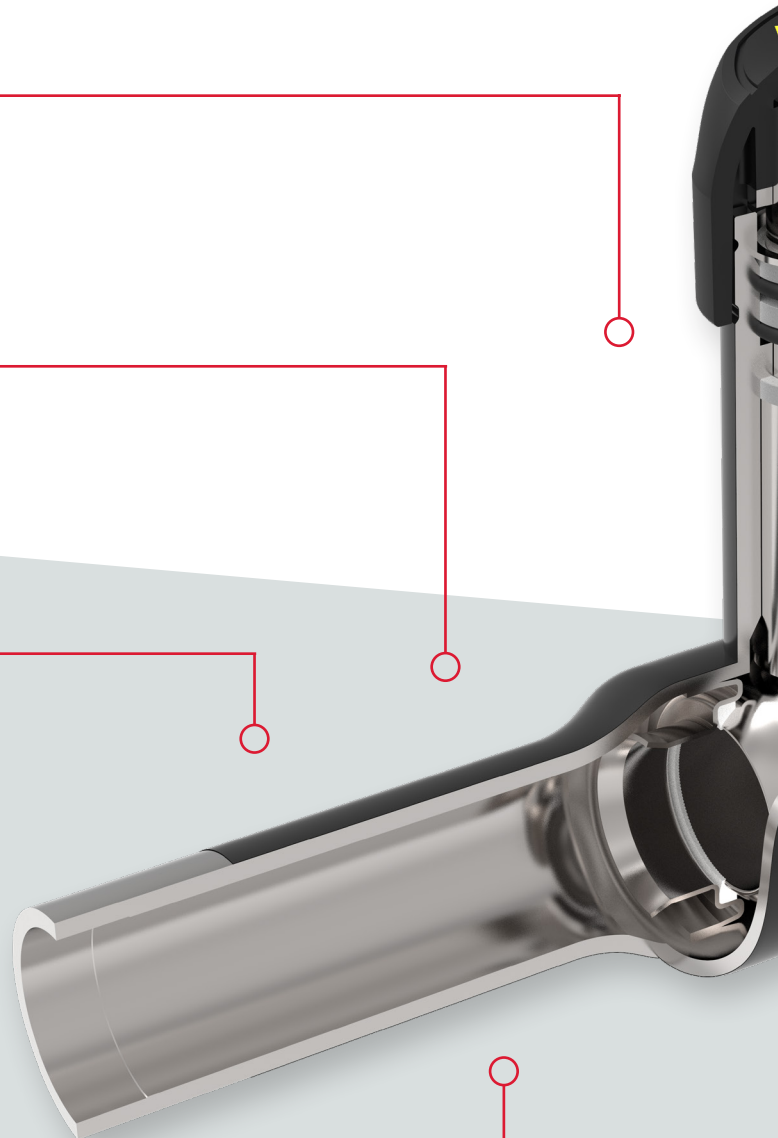

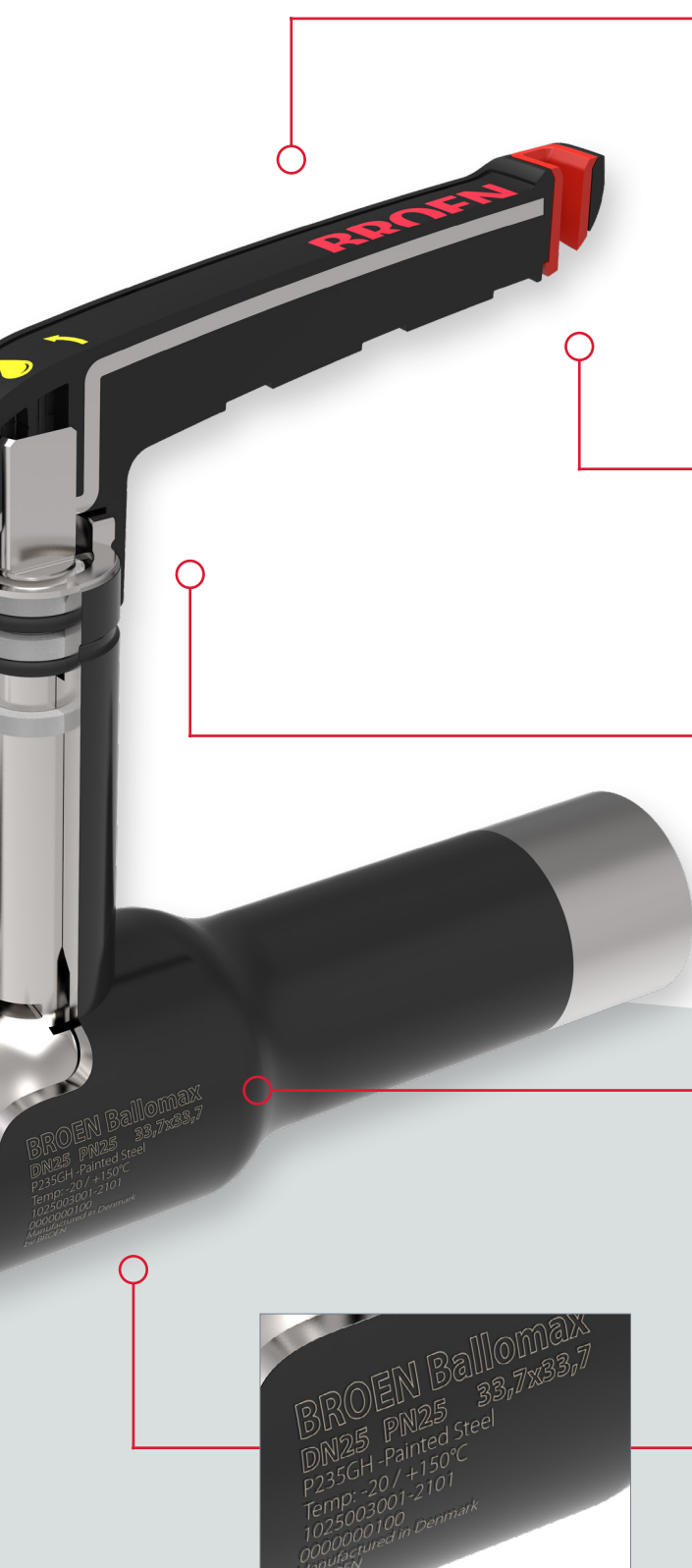

Handle

The solid steel handle is manufactured with fibreglass reinforced nylon around it, in order to create a both durable but also comfortable and ergonomic handle, which does not easily transfer heat. The handle can be mounted in both flow directions with no tools required.

Clips

With interchangeable color clips you can easily visualize forward and return or hot and cold water flows. Furthermore the clips are designed so that a label can be attached to the handle.

Stem

All valves are available with a high stem, which is an integrated part of the valve ensuring proper insulation. The stem is laser welded to the body.

Laser marking

All valves are clearly marked with information about size, material and pressure class.

Proces traceability – unique valve identification

All valves are individually marked with a unique valve number and a data matrix on the spindle underneath the handle with information about process-, quality- and distribution data – for each individual valve.



BROEN BALLOMAX® DN10-50

Product description

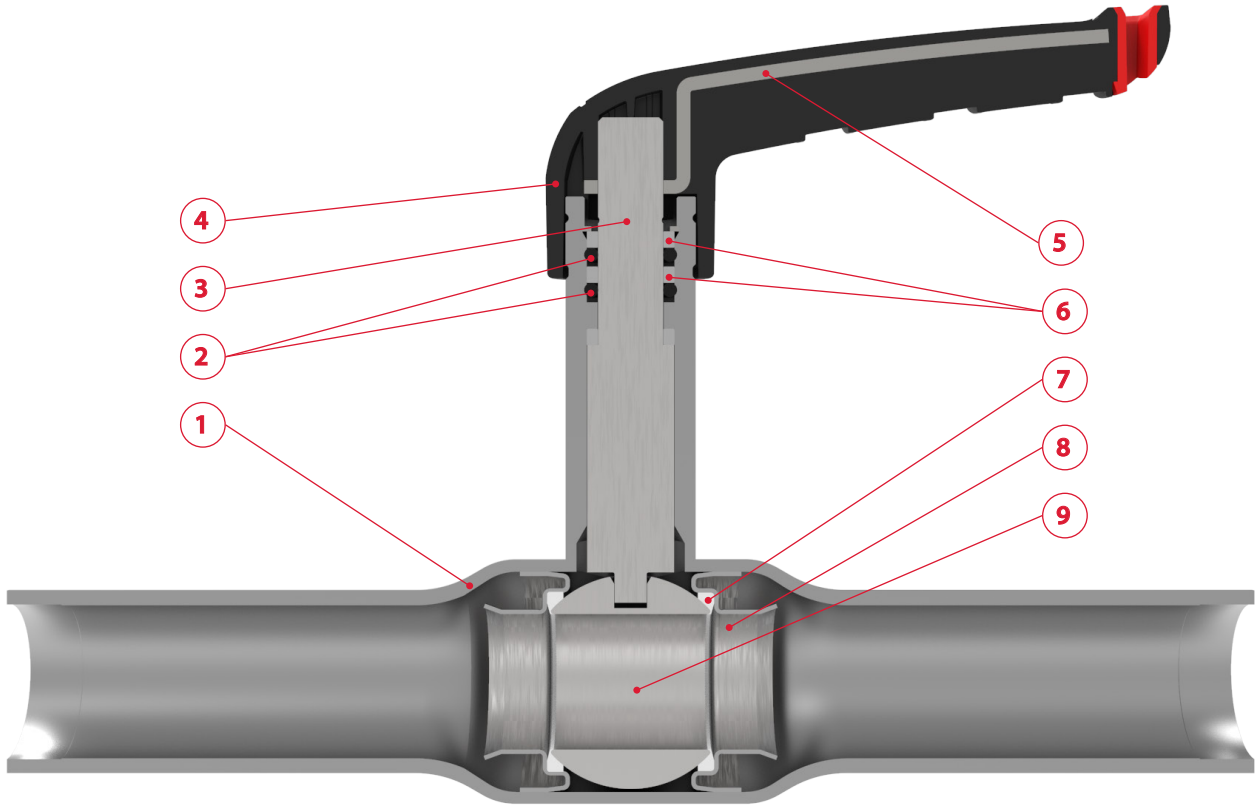

No.	Component	Material	Standard
1	Valve housing	Carbon steel	P235GH / EN 10217-2
2	O-ring	Elastomer - EPDM	
3	Stem	Stainless steel	EN 1.4401 / AISI 316
4	Handle	Fibreglass reinforced nylon	PA66
5	Metal reinforcement	Galvanized steel	

No.	Component	Material	Standard
6	Ring	PTFE, modified 20% C	
7	Seal	TFM™ PTFE	EN 1.4401 / AISI 316
8	Spring supported ring	Stainless steel	EN 1.4301 / AISI 304
9	Ball	Stainless steel	

Same construction applies for other types of connections.

BROEN BALLOMAX®

Technical data

Material, valve housing:	P235GH / EN 10217-2
Material, handle:	Fibreglass reinforced nylon with metal insert
Sizes:	DN10-50
Seals:	TFM™ PTFE (Polytetrafluorethylene)
O-rings:	Elastomer - EPDM (Ethylene Propylene Diene Monomer)
Medium:	Water
Operating pressure:	Max 25 bar
Operating temperature:	-20°C to +150°C
Design temperature:	-20°C to +200°C

Kvs values

DN [mm]	10	15	20	25	32	40	50
Kvs [m ³ /h]	13	26	49	75	110	214	308

Pressure and temperature diagram

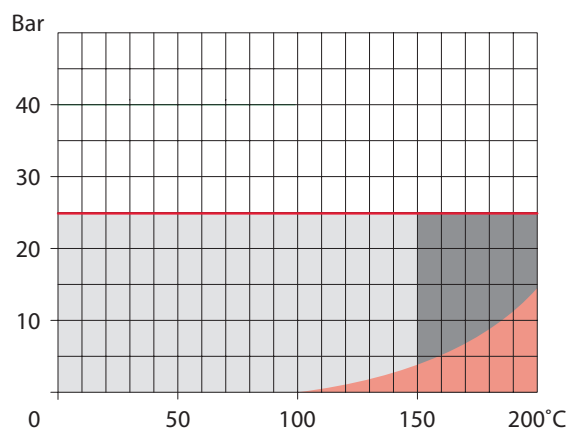

- Normal working area
- Short-term working area
- Steam area (see high temperature valves)

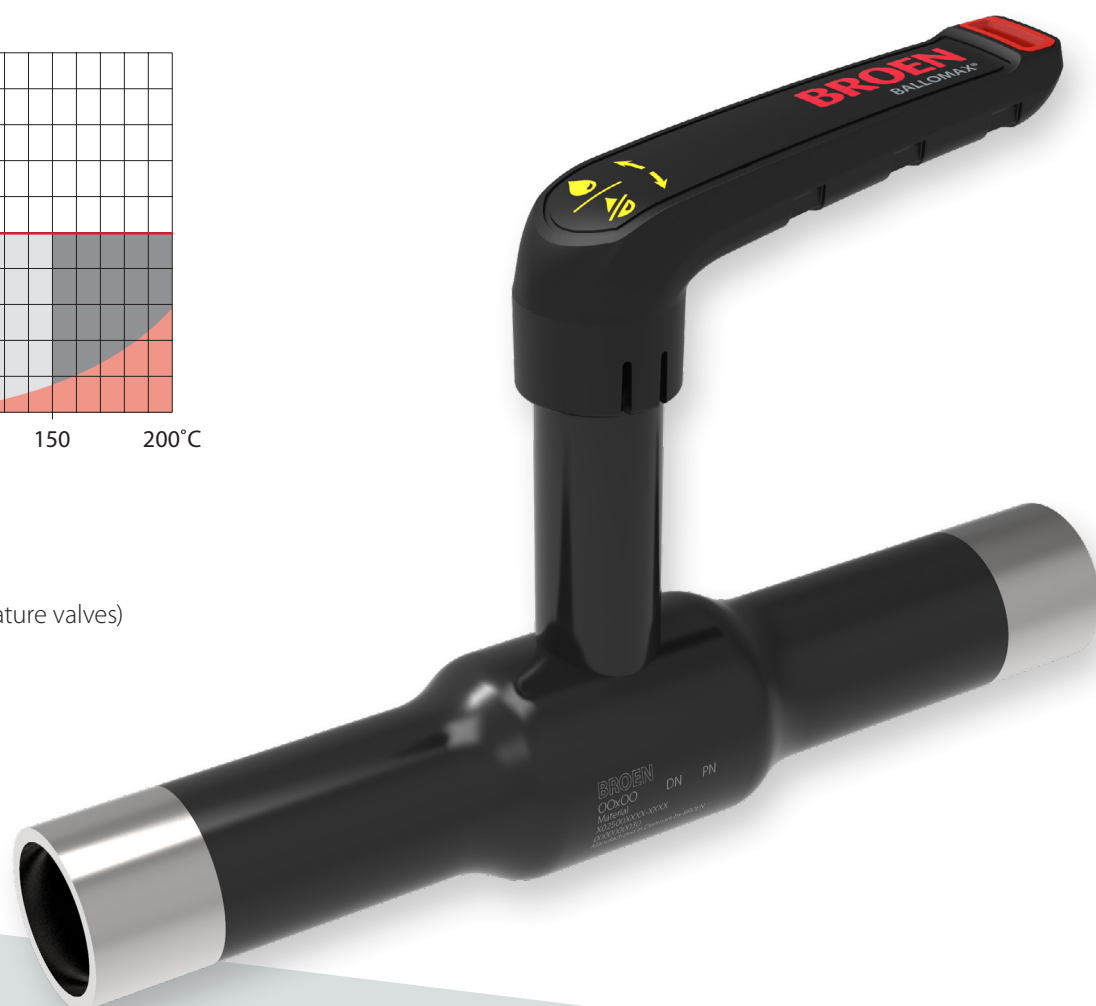

BROEN BALLOMAX® DN10-50

BBM 12031

Female x Female - L handle



DN	BROEN No.	Bore	Kvs	net Weight kg	All dimensions in mm					
					G	DH	L1	H1	H2	A
10	1010002031-2101	10	13	0.30	3/8"	Ø26.0	74	106	55	75
15	1015002031-2101	15	26	0.35	1/2"	Ø30.0	94	108	55	75
20	1020002031-2101	20	49	0.47	3/4"	Ø38.0	104	111	54	75
25	1025002031-2101	25	75	0.80	1"	Ø45.0	112	125	52	100
32	1032002031-2101	32	110	1.21	1 1/4"	Ø56.5	134	131	52	100
40	1040002031-2101	40	214	1.83	1 1/2"	Ø68.0	156	156	63	120
50	1050002031-2101	50	308	3.09	2"	Ø85.0	192	165	63	120

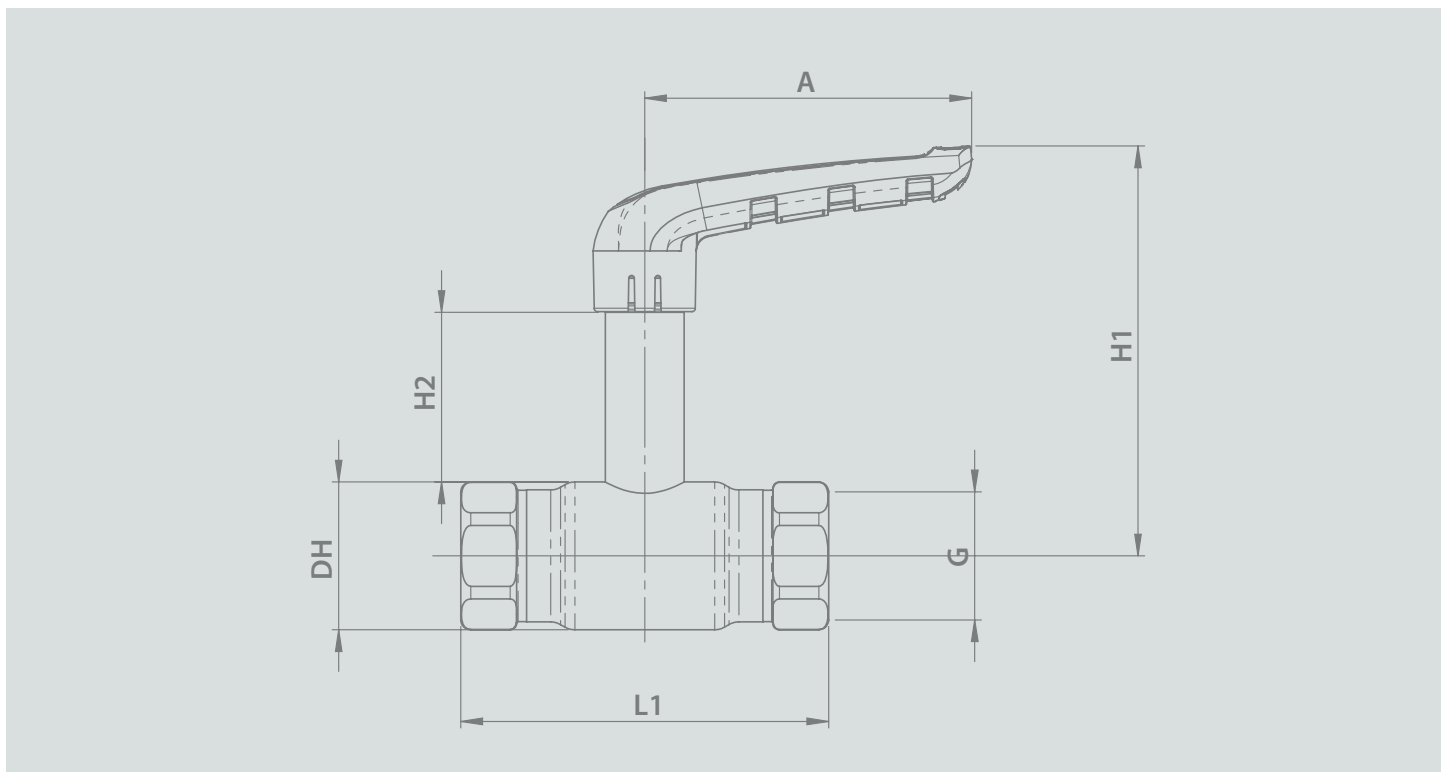

BROEN BALLOMAX® DN10-50

BBM 12031

Female x Female - Gearhandle



DN	BROEN No.	Bore	Kvs	net Weight kg	All dimensions in mm					
					G	DH	L1	H1	H2	A
10	1010002031-2201	10	13	0.35	3/8"	Ø26,0	74	106	55	59
15	1015002031-2201	15	26	0.40	1/2"	Ø30,0	94	108	55	59
20	1020002031-2201	20	49	0.52	3/4"	Ø38,0	104	111	54	59
25	1025002031-2201	25	75	0.85	1"	Ø45,0	112	125	52	81
32	1032002031-2201	32	110	1.26	1 1/4"	Ø56,5	134	131	52	81
40	1040002031-2201	40	214	1.88	1 1/2"	Ø68,0	156	156	63	108
50	1050002031-2201	50	308	3.14	2"	Ø85,0	192	165	63	108

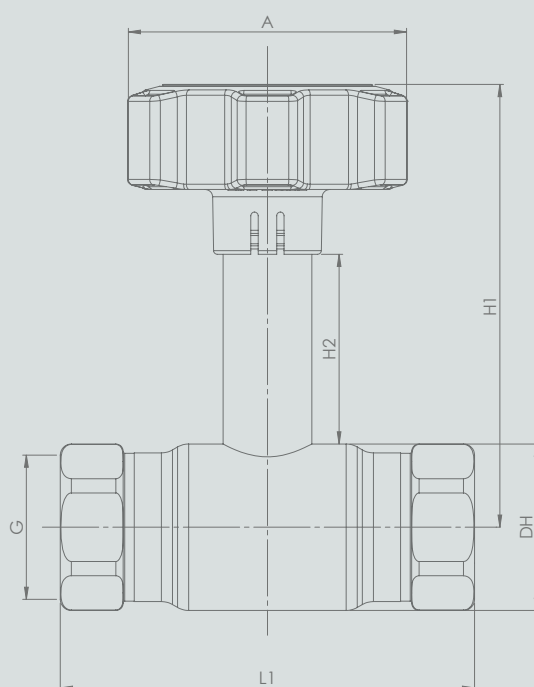

BROEN BALLOMAX® DN10-50 BBM13001

Welding × Welding - L handle



DN	BROEN No.	Bore	Kvs	net Weight kg	All dimensions in mm						
					DH	d	t	L1	H1	H2	A
10	1010003001-2101	10	13	0.20	Ø26,0	17.2	1.8	210	106	55	75
15	1015003001-2101	15	26	0.22	Ø30,0	21.3	2.0	210	108	55	75
20	1020003001-2101	20	49	0.58	Ø38,0	26.9	2.3	230	111	54	75
25	1025003001-2101	25	75	0.91	Ø45,0	33.7	2.6	230	125	52	100
32	1032003001-2101	32	110	1.30	Ø56,5	42.4	2.6	260	131	52	100
40	1040003001-2101	40	214	1.86	Ø68,0	48.3	2.6	260	156	63	120
50	1050003001-2101	50	308	3.00	Ø85,0	60.3	2.9	290	165	63	120

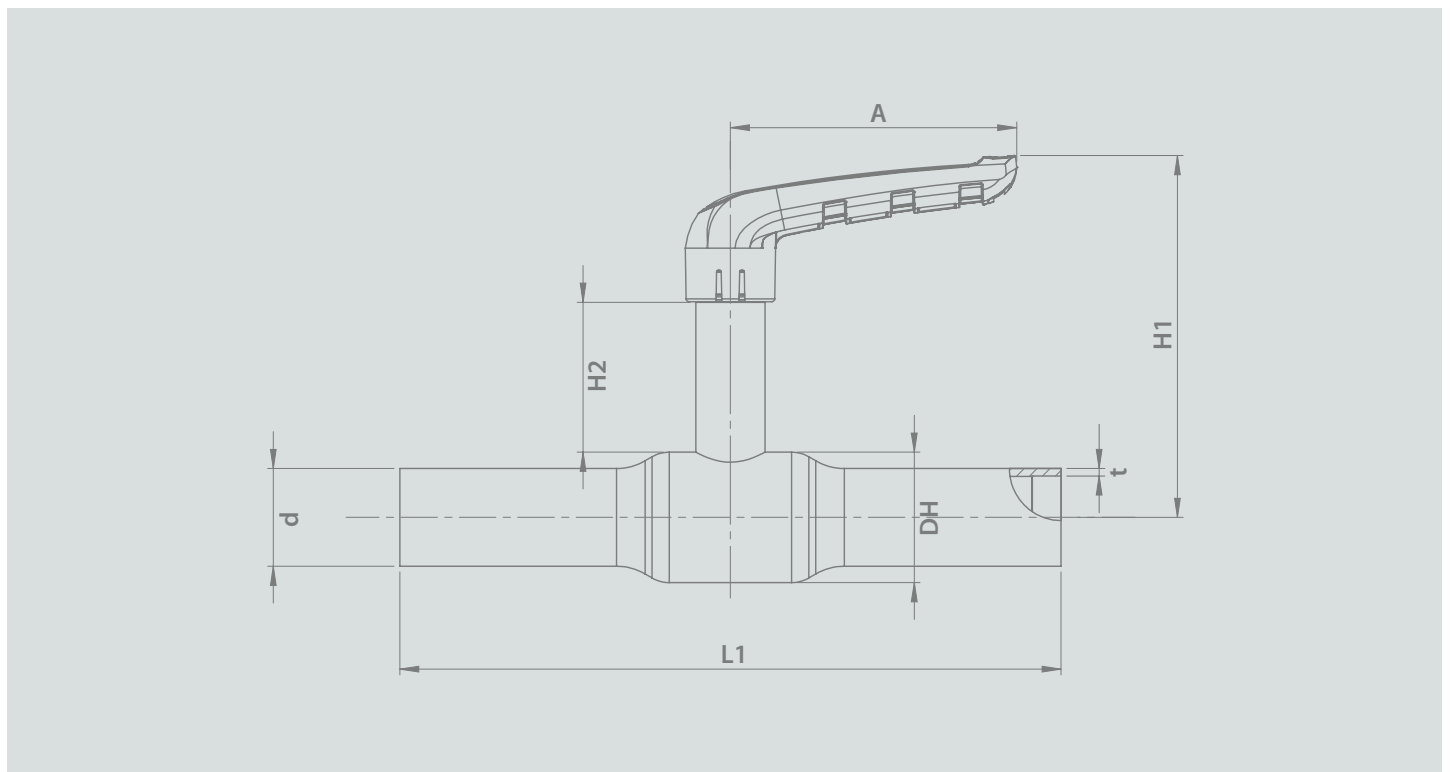

BROEN BALLOMAX® DN10-50 BBM13001

Welding × Welding - Gearhandle



DN	BROEN No.	Bore	Kvs	net Weight kg	All dimensions in mm						
					DH	d	t	L1	H1	H2	A
10	1010003001-2201	10	13	0.25	Ø26.0	17.2	1.8	210	106	55	59
15	1015003001-2201	15	26	0.27	Ø30.0	21.3	2.0	210	108	55	59
20	1020003001-2201	20	49	0.63	Ø38.0	26.9	2.3	230	111	54	59
25	1025003001-2201	25	75	0.96	Ø45.0	33.7	2.6	230	125	52	81
32	1032003001-2201	32	110	1,35	Ø56.5	42.4	2.6	260	131	52	81
40	1040003001-2201	40	214	1.91	Ø68.0	48.3	2.6	260	156	63	108
50	1050003001-2201	50	308	3.05	Ø85.0	60.3	2.9	290	165	63	108

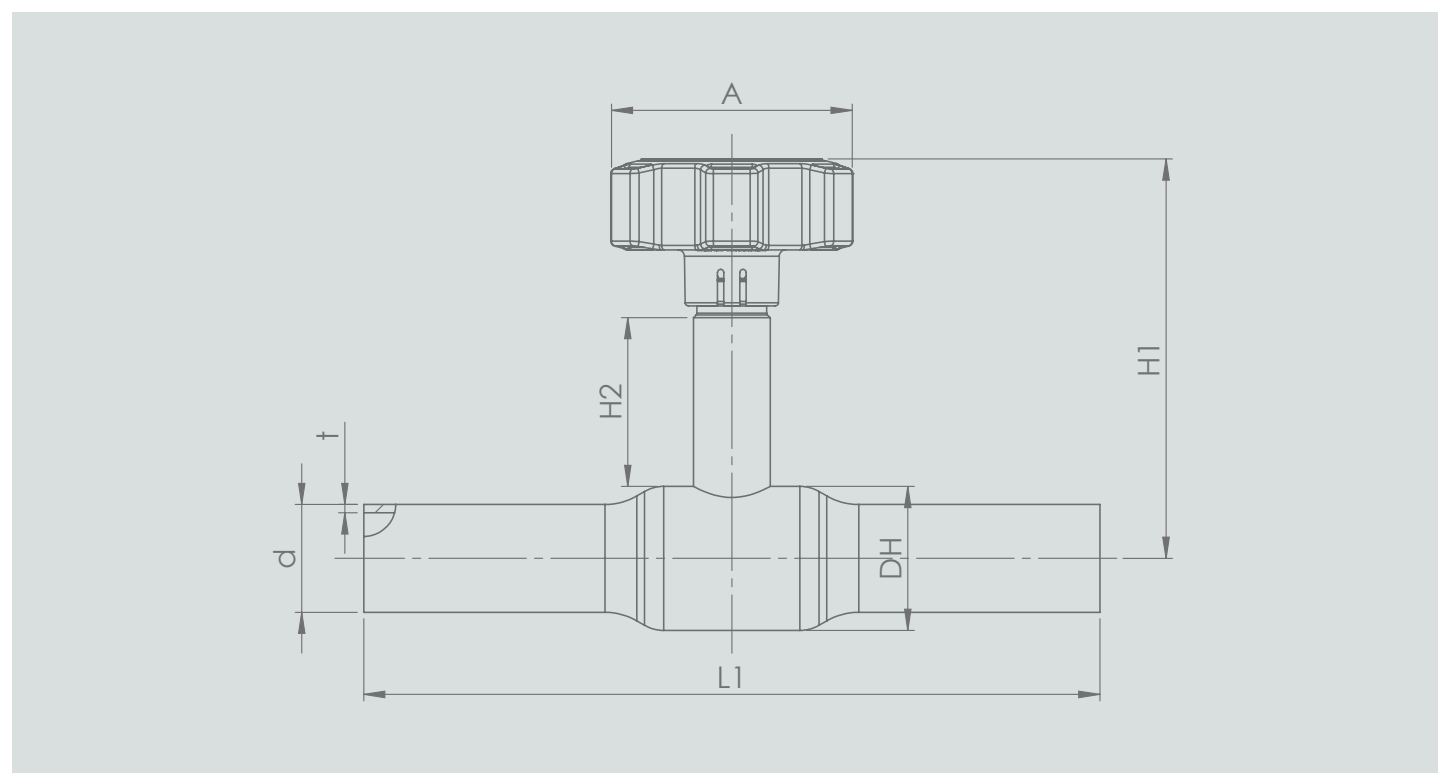

BROEN BALLOMAX® DN10-50 BBM13601

Welding × Female - L handle



DN	BROEN No.	Bore	Kvs	net Weight kg	All dimensions in mm								
					G	DH	d	t	L1	L2	H1	H2	A
10	1010003601-2101	10	13	0.30	3/8"	Ø26.0	17,2	1,8	37	105	106	55	75
15	1015003601-2101	15	26	0.38	1/2"	Ø30.0	21,3	2	40	105	108	55	75
20	1020003601-2101	20	49	0.56	3/4"	Ø38.0	26,9	2,3	52	115	111	54	75
25	1025003601-2101	25	75	0.86	1"	Ø45.0	33,7	2,6	56	115	125	52	100
32	1032003601-2101	32	110	1.27	1 1/4"	Ø56.5	42,4	2,6	67	130	131	52	100
40	1040003601-2101	40	214	1.90	1 1/2"	Ø68.0	48,3	2,6	78	134	156	63	120
50	1050003601-2101	50	308	3.09	2"	Ø85.0	60,3	2,9	96	145	165	63	120

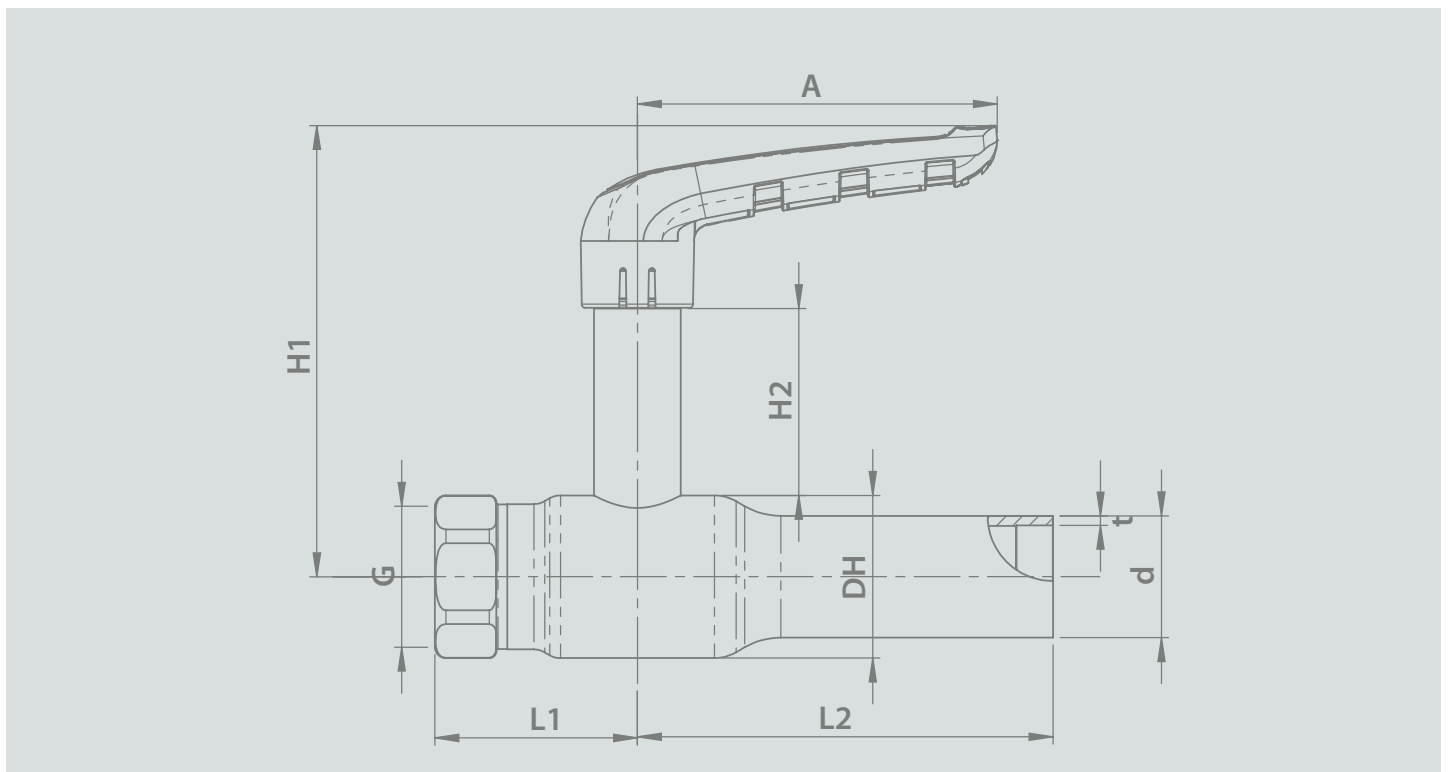

BROEN BALLOMAX® DN10-50 BBM13601

Welding × Female - Gearhandle



DN	BROEN No.	Bore	Kvs	net Weight kg	All dimensions in mm								
					G	DH	d	t	L1	L2	H1	H2	A
10	1010003601-2201	10	13	0.35	3/8"	Ø26.0	17.2	1.8	37	105	106	55	59
15	1015003601-2201	15	26	0.43	1/2"	Ø30.0	21.3	2.0	40	105	108	55	59
20	1020003601-2201	20	49	0.61	3/4"	Ø38.0	26.9	2.3	52	115	111	54	59
25	1025003601-2201	25	75	0.91	1"	Ø45.0	33.7	2.6	56	115	125	52	81
32	1032003601-2201	32	110	1.32	1 1/4"	Ø56.5	42.4	2.6	67	130	131	52	81
40	1040003601-2201	40	214	1.95	1 1/2"	Ø68.0	48.3	2.6	78	134	156	63	108
50	1050003601-2201	50	308	3.14	2"	Ø85.0	60.3	2.9	96	145	165	63	108

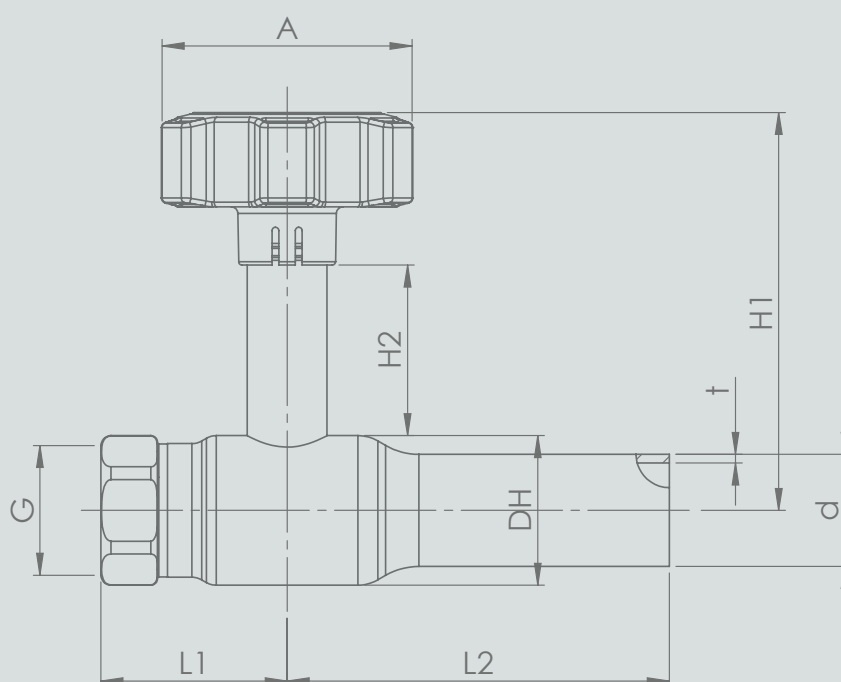

BROEN BALLOMAX® DN10-50 BBM13701

Malee × Welding - L handle



DN	BROEN No.	Bore	Kvs	net Weight kg	All dimensions in mm								
					G	DH	d	t	L1	L2	H1	H2	A
10	1010003701-2101	10	13	0.30	3/8"	Ø26.0	17.2	1.8	42	105	106	55	75
15	1015003701-2101	15	26	0.38	1/2"	Ø30.0	21.3	2.0	47	105	108	55	75
20	1020003701-2101	20	49	0.52	3/4"	Ø38.0	26.9	2.3	56	115	111	54	75
25	1025003701-2101	25	75	0.87	1"	Ø45.0	33.7	2.6	67	115	125	52	100
32	1032003701-2101	32	110	1.30	1 1/4"	Ø56.5	42.4	2.6	79	130	131	52	100
40	1040003701-2101	40	214	1.93	1 1/2"	Ø68.0	48.3	2.6	88	134	156	63	120
50	1050003701-2101	50	308	3.18	2"	Ø85.0	60.3	2.9	112	145	165	63	120

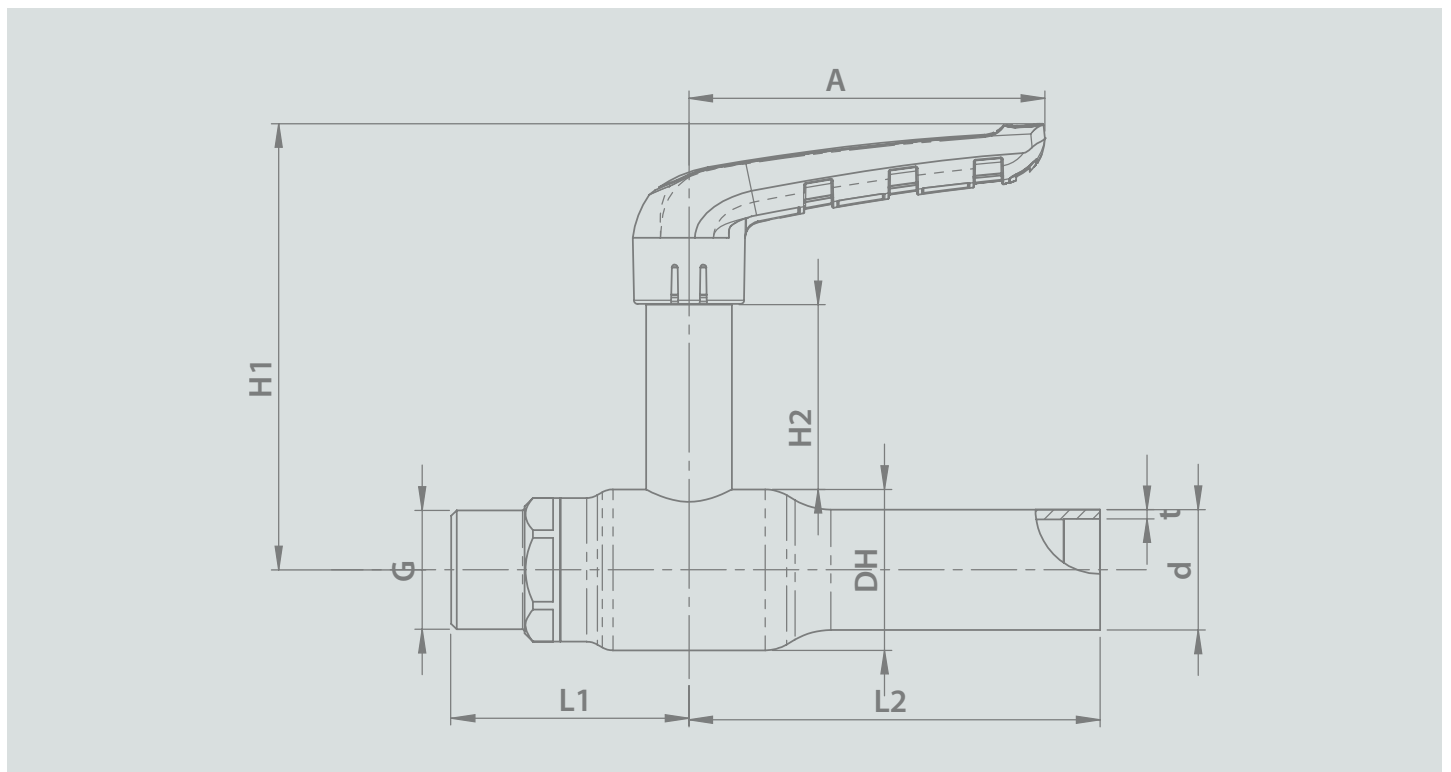

BROEN BALLOMAX® DN10-50

BBM13701

Malee × Welding - Gearhandle



DN	BROEN No.	Bore	Kvs	net Weight kg	All dimensions in mm								
					G	DH	d	t	L1	L2	H1	H2	A
10	1010003701-2201	10	13	0.35	3/8"	Ø26.0	17.2	1.8	37	105	106	55	59
15	1015003701-2201	15	26	0.43	1/2"	Ø30.0	21.3	2.0	40	105	108	55	59
20	1020003701-2201	20	49	0.57	3/4"	Ø38.0	26.9	2.3	52	115	111	54	59
25	1025003701-2201	25	75	0.82	1"	Ø45.0	33.7	2.6	56	115	125	52	81
32	1032003701-2201	32	110	1.35	1 1/4"	Ø56.5	42.4	2.6	67	130	131	52	81
40	1040003701-2201	40	214	1.98	1 1/2"	Ø68.0	48.3	2.6	78	134	156	63	108
50	1050003701-2201	50	308	3.23	2"	Ø85.0	60.3	2.9	96	145	165	63	108

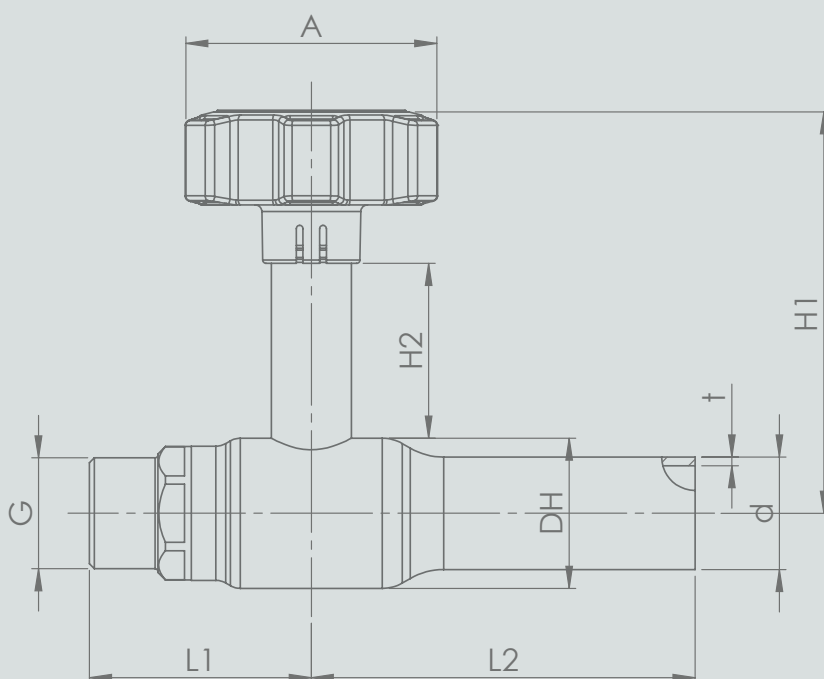

Our brand is our promise

BROEN
VALVE TECHNOLOGIES

BROEN VALVE TECHNOLOGIES

BROEN is a leading international manufacturer of valve technology and we operate on three continents across the world with key markets in Europe, China and USA.

For more than 70 years BROEN has been the global leader in the development and production of valve technology for the control of water, air and gas. BROEN delivers complete solutions for HVAC building installations and is a leading supplier of district energy valves and valve technology for natural gas.

We know application and valve technology in depth and in close dialogue with our customers and partners all over the world we create value and reliability with proven valves offering full quality assurance.

BROEN is headquartered in Assens, Denmark and is part of Aalberts N.V. listed on the EuroNext Stock Exchange (NL).

Read more at: www.broen.com

Sales- and productions sites ●

BROEN A/S, Assens (DK)
BROEN POLAND, Dzierżoniów (PL)
BROEN POLAND, Rogoźno (PL)
BROEN INC., Houston (US)
BROEN Clorius, Dzierżoniów (PL)

Sales companies and offices ○

BROEN Assens (DK)
BROEN Helsinki (FI)
BROEN AB (SE)
BROEN SEI, Bucharest (RO)
BROEN Beijing (CN)
BROEN Clorius, Shanghai (CN)

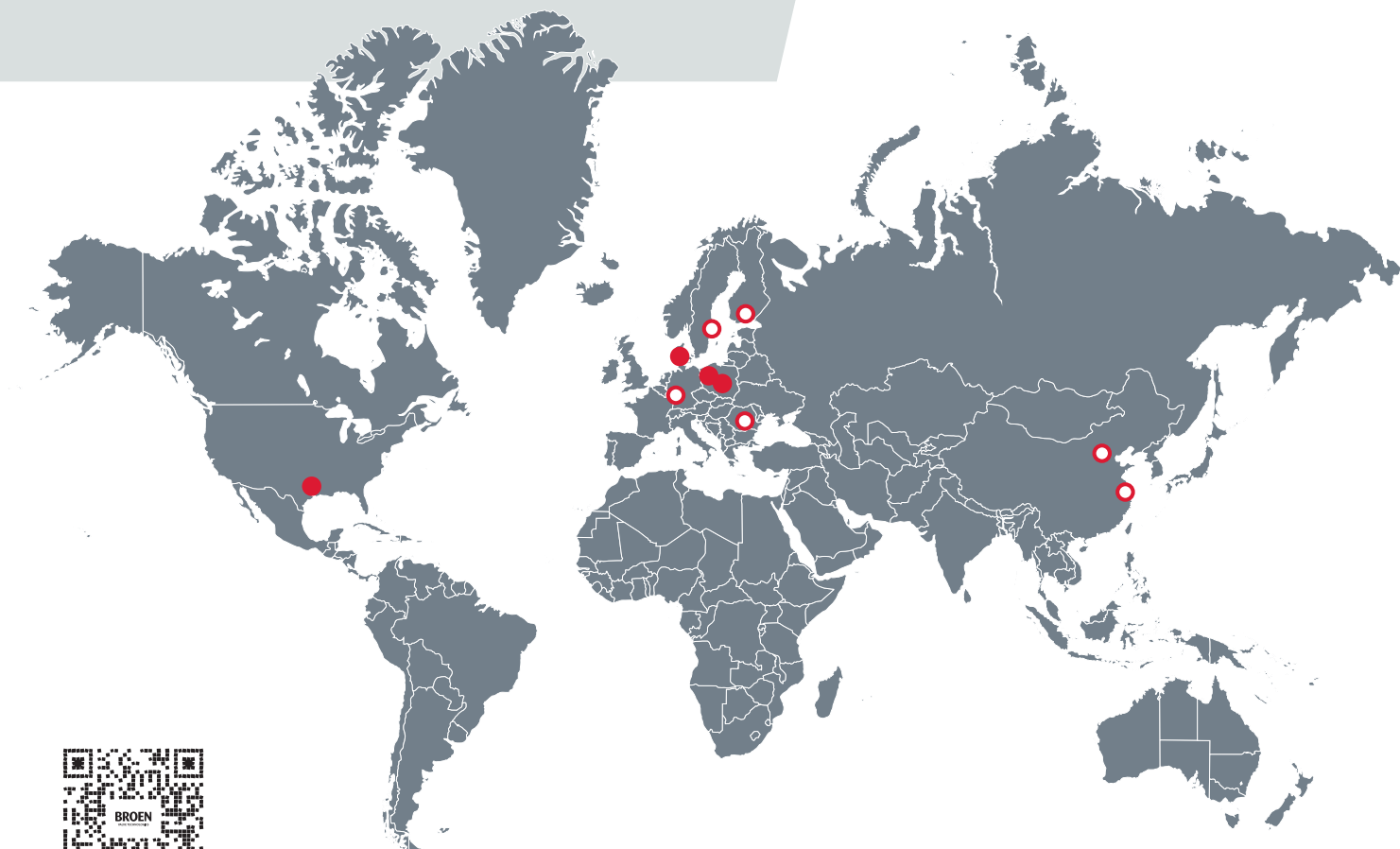

For further information,
scan this QR code or visit
www.broen.com