

3-way Control Valve type G3FM-TL (AB-Left)

Nodular cast iron, PN25, DN 65 – 125 mm / PN16, DN150 - 300 mm / PN10, DN 350 - 800 mm

0-2.6.03-G

Page 1 of 4



TECHNICAL DATA

Materials:

- Valve body, slide	Nodular cast iron EN-GJS-400-15
- O-ring	NBR 70A
- U-ring	PTFE
Flow characteristic	Almost linear
Leakage rate	Max. 0.5%
Regulating capability	Kvs/Kvr > 25

Flanges	EN 1092-2 PN 10/16
- Option	JIS B 2210 5K

Counter flanges (suggested for EN 1092-2)

DIN 2632 – PN 10
DIN 2633 – PN 16

Max. pressure Δp_L , against which the valve can close:

- DN 65 - 125	25 bar
- DN 150-300	16 bar
- DN 350-800	10 bar

Nominal pressure

- DN 65-125 mm	PN 25 max. 100°C (option 250°C)
- DN 150-300 mm	PN 16, max. 100°C (option 250°C)
- DN 350-800 mm	PN 10, max. 100°C (option 250°C)
- DN 150-800 mm	JIS 5K (option)

Slide in Nodular cast iron

APPLICATIONS

Control valve type G3FM-TL is a three-way control valve with a slide for quarter turn operation designed for regulating of fresh water, lubricating oil and other liquid media. The valves are designed for use in conjunction with industrial processes, district heating and marine installations with large water or lubricating oil volumes:

- Engine Jacket Cooling Water System
- Lubricating Oil Cooling
- Central Cooling Water System, etc.

The valves are designed for use in conjunction with valve motor type CAR with handle for manual operation or for use in conjunction with a pneumatic actuator.

DESIGN

The valve body and the valve slide are made of nodular cast iron. The valve flanges are drilled according to EN 1092-2 (JIS B 2210 option).

FUNCTION

The slide is firmly connected with the motor spindle. When the slide is in the one outer position by turning the spindle, connection A-AB is fully open and connection B-AB is fully closed. In the other outer position connection A-AB is fully closed and connection B-AB is fully open. In the intermediate positions the opening degrees change proportionally. The valve has a small tolerance between body and slide. To minimize the leakage an O-ring is mounted in a groove on the slide.

FEATURES

- Simple design secures reliable controls and reduces costly downtime.
- Low leakage rate secures energy savings.
- Flexible choice of port placement

PRESSURE/TEMPERATURE DIAGRAM

According to DIN 2401

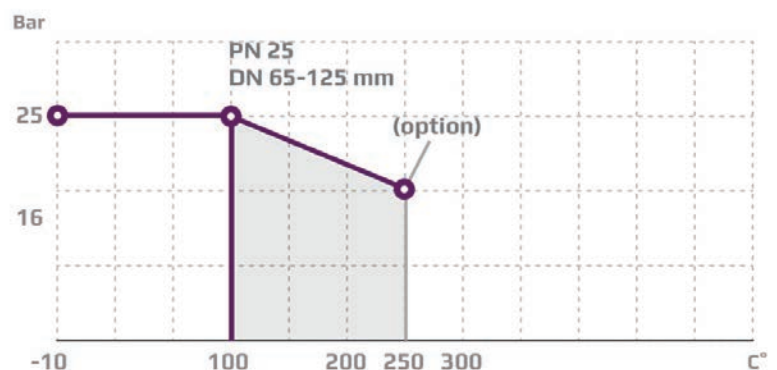

PRESSURE/TEMPERATURE DIAGRAM

According to DIN 2401

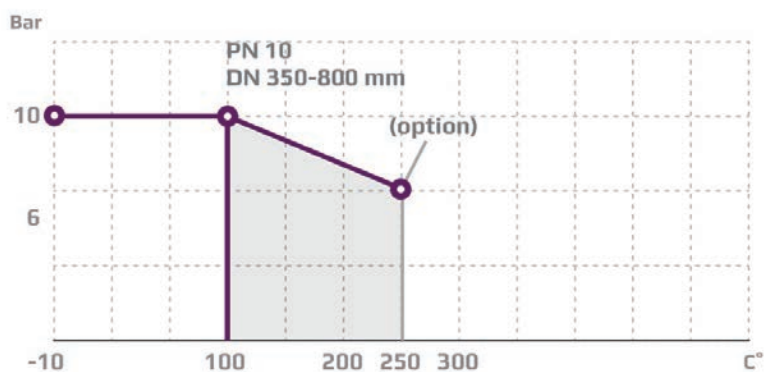
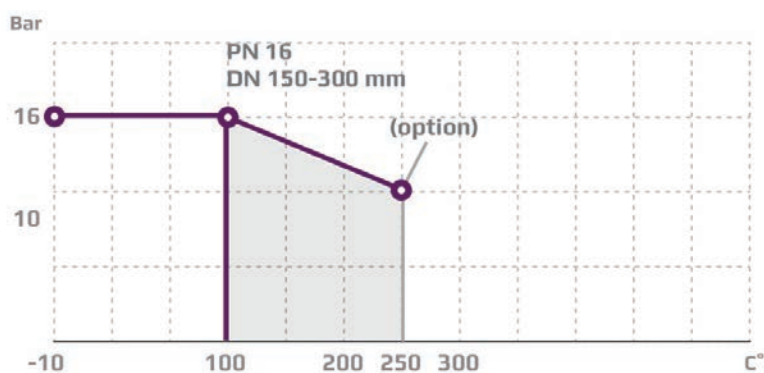

PORT NUMBERING

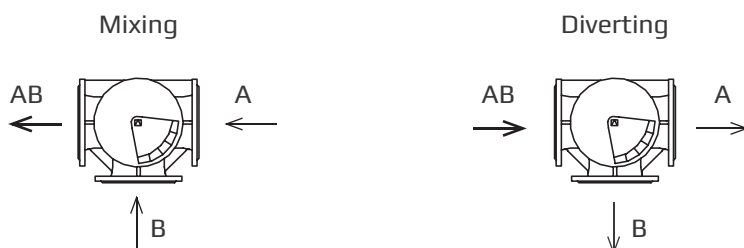

MOUNTING

The valve connections are marked A, B and AB. The slide is operating between A and B. Check slide position before installation in the pipe. The slide position is marked on the top of the shaft. The valves can be installed with vertical as well as horizontal spindles. The valves must be mounted in a way that the valve actuator will be exposed to a minimum of moisture and unnecessary vibrations. Valves can also be supplied in AB-Right configuration (data sheet 0.2.6.02).

3-way Control Valve type G3FM-TL (AB-Left)

Nodular cast iron, PN25, DN 65 – 125 mm / PN16, DN150 - 300 mm / PN10, DN 350 - 800 mm

0-2.6.03-G

Page 3 of 4

DIMENSION SKETCH

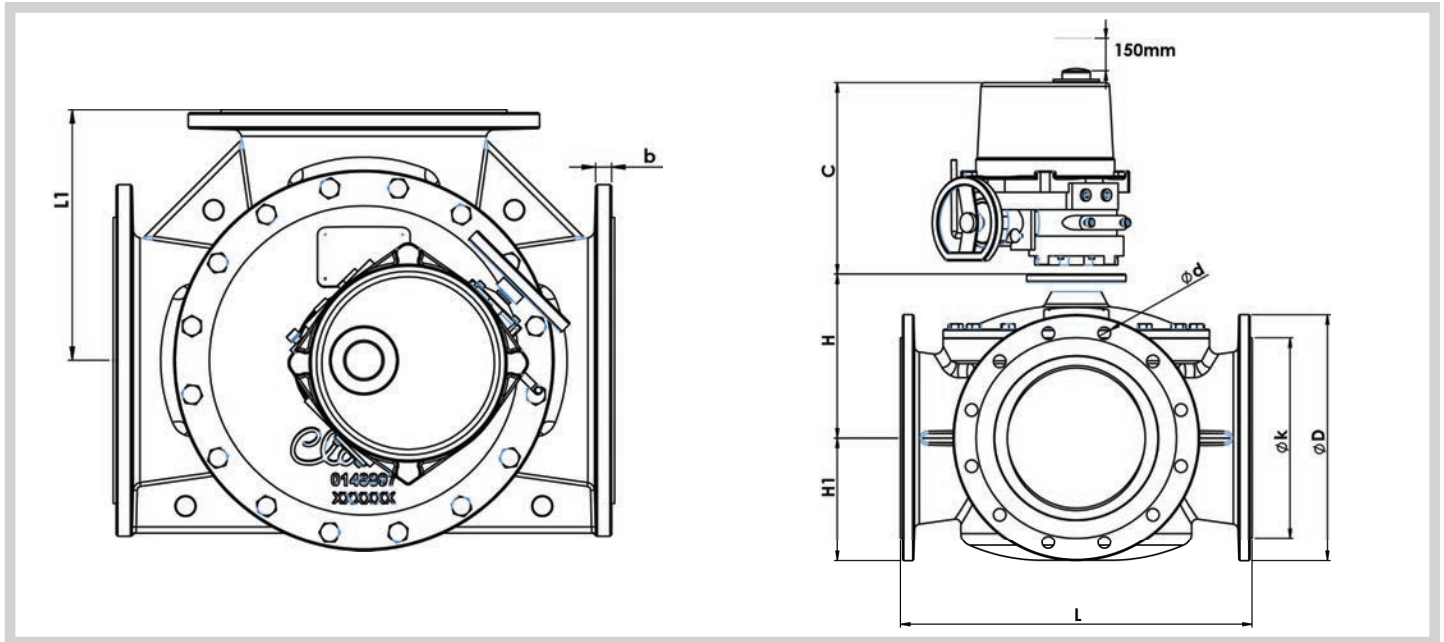

Type	L (mm)	L1 (mm)	H (mm)	H1 (mm)	b (mm)	C (mm)	EN 1092-2			ANSI Class 150			JIS B 2210 5K			JIS B 2210 10K		
							D (dia.) (mm)	k (dia.) (mm)	d mm dia. (number)	D (dia.) (mm)	k (dia.) (mm)	d mm dia. (number)	D (dia.) (mm)	k (dia.) (mm)	d mm dia. (number)	D (dia.) (mm)	k (dia.) (mm)	d mm dia. (number)
65 G3FM-TL	292	146	135	90	20	273	185	145	19x(8)	180	140	19x(4)	155	130	15x(4)	175	140	19x(4)
80 G3FM-TL	292	146	140	94	20	273	200	160	19x(8)	190	152	19x(4)	180	145	19x(4)	185	150	19x(8)
100 G3FM-TL	350	175	158	112	17	273	235	190	23x(8)	230	190.9	19x(8)	200	165	19x(8)	210	175	19x(8)
125 G3FM-TL	400	200	179	123	17	273	270	220	28x(8)	255	216	22x(8)	235	200	19x(8)	250	210	23x(8)
150 G3FM-TL	438	219	196	139	20	276	290	240	23x(8)	280	241	22x(8)	265	230	19x(8)	280	240	23x(8)
200 G3FM-TL	530	270	236	175	21	361	340	295	23x(12)	343	299	23x(8)	320	280	23x(8)	320	290	23x(12)
250 G3FM-TL	592	300	273	205	23	361	400	355	28x(12)	407	362	26x(12)	385	345	23x(12)	400	355	25x(12)
300 G3FM-TL	649	330	305	230	25.5	361	455	410	28x(12)	483	432	26x(12)	430	390	23x(12)	445	400	25x(16)
350 G3FM-TL	717	360	337	255	25.5	361	505	460	23x(16)	534	477	29x(12)	480	435	25x(12)	490	445	25x(16)
400 G3FM-TL	770	385	375	285	26	361	565	515	28x(16)	597	540	29x(16)	540	495	25x(16)	560	510	27x(16)
450 G3FM-TL	820	410	391	310	26.5	556	615	565	28x(20)	635	578	32x(16)	605	555	25x(16)	620	565	27x(20)
500 G3FM-TL	900	455	425	340	27.5	556	670	620	28x(20)	699	635	32x(20)	655	605	25x(20)	675	620	27x(20)
550 G3FM-TL	900	455	425	373	27.5	556							720	665	27x(20)	745	680	33x(20)
600 G3FM-TL	1000	505	470	393	31.0	556	780	725	31x(20)	813	750	35x(20)	770	715	25x(20)	795	730	33x(24)
700 G3FM-TL	1106	553	519	462	34.0	556	895	840	31x(24)				875	820	27x(24)	905	840	33x(24)
800 G3FM-TL	1230	615	650	465	53		1015	950	34x(24)				995	930	33x(24)	1020	950	33x(28)

SPECIFICATIONS

Type	Flange connection DN in mm	k_{vs} -value ⁽¹⁾ Mixing valve m ³ /h	k_{vs} -value ⁽¹⁾ Diverting valve m ³ /h	Torque Nm	Weight kg
65 G3FM-TL	65	95	120	46	26
80 G3FM-TL	80	122	154	49	29
100 G3FM-TL	100	175	220	52	41
125 G3FM-TL	125	245	330	98	58
150 G3FM-TL	150	395	425	135	71
200 G3FM-TL	200	800	1100	330	114
250 G3FM-TL	250	1500	2100	450	159
300 G3FM-TL	300	2000	2650	700	207
350 G3FM-TL	350	2530	3380	780	278
400 G3FM-TL	400	3050	3950	880	346
450 G3FM-TL	450	3680	4480	1250	433
500 G3FM-TL	500	4150	5250	1850	563
550 G3FM-TL	550	4150	5250	1850	575
600 G3FM-TL	600	4800	6050	2300	816
700 G3FM-TL	700	5500	7000	4500	TBC
800 G3FM-TL	800	6200	8000	4650	2100

