

3-way Control Valve type G3FA-HT

Nodular cast iron, PN 16, DN 80 – 200 mm / PN 10, DN 300/250 – 300 mm

HIGH TEMPERATURE (TEFLON GRAPHITE SEALING)

0-2.5.17.01-B

Page 1 of 2

APPLICATIONS

Control valves type G3FA-HT are designed for regulating of fresh water, lubricating oil and other liquid media. The valves are designed for use in conjunction with large industrial processes, district heating and marine installations, e.g. cooling of main and auxiliary engines. The valve is used in conjunction with Clorius valve motor type MT90 Marine.

DESIGN

The valve components (seats and cone) are made of alubronze, the spindle of stainless steel. The valve body is made of nodular cast iron and the valve flanges are drilled according to EN 1092-2.

FUNCTION

The valve cone is firmly connected with the motor spindle. When the valve cone is in the one extreme position by draw on the spindle, connection A-AB is kept fully open and connection B-AB is fully closed. In the other extreme position connection A-AB is fully closed and connection B-AB is fully open. In the intermediate positions the opening degrees change proportionally.

FEATURES

- Can be used for both mixing and diverting
- Simple design secures reliable controls and reduces costly downtime.
- Location of the pack box in the actuator makes the valve service friendly

PRESSURE/TEMPERATURE DIAGRAM

According to DIN 2401

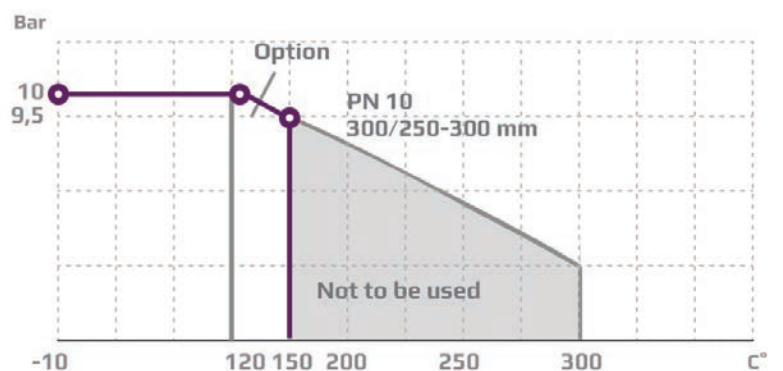
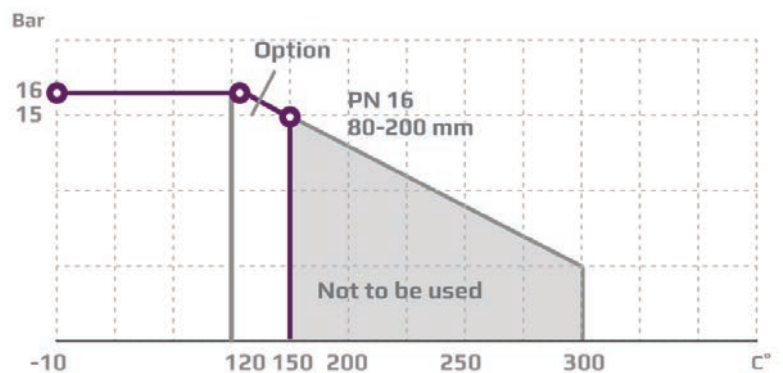

TECHNICAL DATA

Materials:

- Valve body	Nodular cast iron EN-GJS-400-15
- Seats and cone	Alu Bronze CuAL10Fe5Ni5
- Spindle	Stainless steel (W.no 1.4436)
- O-ring	A75H
- Gasket	Reinz-AFM34

Nominal pressure

- 80-200 G3FA-HT:	PN 16 (max.120/150°C)
- 300/250-300 G3FA-HT:	PN 10 (max.120/150°C)

Seats 2 balanced single seats

Flow characteristic Almost linear

Leakage rate $\leq 0.5\%$

Regulating capability Kvs/Kvr > 25

Flanges According to EN 1092-2, PN 16 & PN 10

Note !

Valve type 200/175 G3FA has outer measures and flanges drilled as valve type 200 G3FA. Valve type 300/250 G3FA has outer measures and flanges drilled as valve type 300 G3FA.

Counter flanges (suggested for EN 1092-2)

- 80-200 G3FA-HT:	DIN 2633 – PN 16
- 300/250-300 G3FA-HT:	DIN 2632 – PN 10

For cooling and heating purposes

Subject to change without notice.

PORT NUMBERING

The ports of valves type G3FA-HT are marked with the letters AB, A and B. The letters in parentheses refer to the corresponding internationally adapted designations.

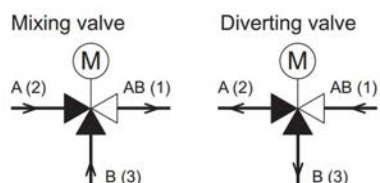

Port AB (1)
Port A (2)
Port B (3)

common port always open
closes at load on spindle
opens at load on spindle



MOUNTING

The valves can be installed vertical as well as horizontal. The valves must be mounted in a way that the valve motor will be exposed to a minimum of moisture and unnecessary vibrations. Free height above / below the valve must be minimum 400 mm for mounting and operation of the AVM/AVF 234 motor, otherwise minimum 745 mm for pneumatic actuators.

DIMENSION SKETCH

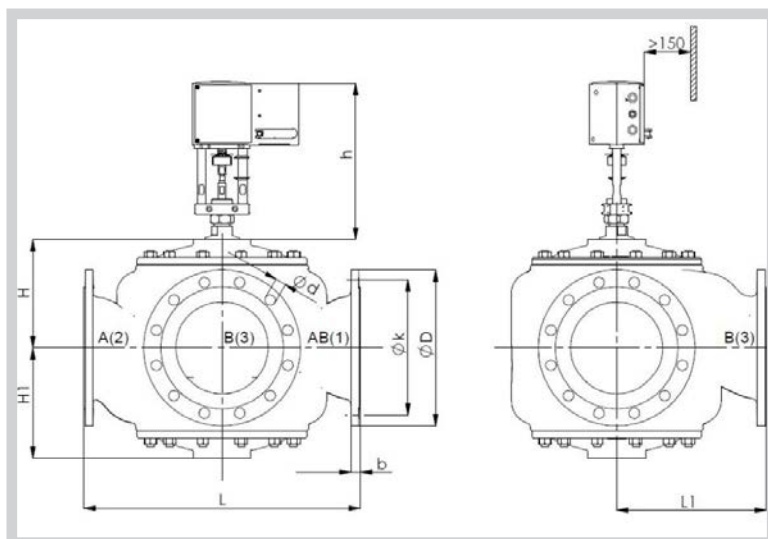

Type	L mm	L1 mm	H mm	H1 mm	b mm	D (dia.) mm	k (dia.) mm	d mm dia. (number)
80 G3FA-HT	310	155	117	127	19	200	160	19x(8)
100 G3FA-HT	350	175	132	141	19	220	180	19x(8)
125 G3FA-HT	400	240	181	171	19	250	210	19x(8)
150 G3FA-HT	480	270	216	189	24	285	240	23x(8)
200/175 G3FA-HT	600	325	238	238	20	340	295	23x(12)
200 G3FA-HT	600	325	238	238	20	340	295	23x(12)
300/250 G3FA-HT	850	450	305	305	25	445	400	23x(12)
300 G3FA-HT	850	450	305	305	25	445	400	23x(12)

SPECIFICATIONS

Type	Flange connection DN in mm	Opening mm	k _{vs} -value ¹⁾ m ³ /h	Lifting height mm	Weight kg
80 G3FA-HT	80	80	80	11	35
100 G3FA-HT	100	100	125	13	44
125 G3FA-HT	125	125	215	18	72
150 G3FA-HT	150	150	310	20	111
200/175 G3FA-HT	200	200	425	22	165
200 G3FA-HT	200	200	555	28	160
300/250 G3FA-HT	300	300	865	28	306
300 G3FA-HT	300	300	1250	45	290

¹⁾ The stated kvs values apply for mixing valves. Diverting valves: 0.86 x (kvs-values for mixing valves).