

2-way Control Valve type L2SR

Gun metal, PN 16, DN 40 – 50 mm, 2 seats, Reverse acting

0-2.2.06-L

Page 1 of 2



APPLICATIONS

Valves type L2SR are mainly intended for control of cooling water, sea water and lubricating liquids. The valves are used in conjunction with temperature- or pressure differential regulators in industrial processes or marine installations - especially in control systems for cooling. As the reverse acting valves are held in closed position by means of a built-in spring, the max. differential pressure, Δp_L , against which a valve can close depends on the spring and when opening the valve, the actuator has to overcome the spring force.

DESIGN

The valve body, seats and cone – are made of gun metal RG 5 and the stem of stainless steel – the valve body with threaded ends according to ISO 7-1. The thread for the actuator connection is G1B. The valves are double-seated. The leakage rate is less than 0.5% of the full flow (according to VDI/VDE 2174).

FUNCTION

REVERSE ACTING

Without an actuator being connected, the valve is held in closed position by means of a spring. With pressure on the spindle the valve opens. In connection with thermostats, pneumatic or electric valve actuators. The valves act as “cooling” valves, i.e. they open at rising temperatures.

FEATURES

- Simple design secures reliable controls and reduces costly downtime.
- Location of the pack box in the actuator makes the valve service friendly.

TECHNICAL DATA

Materials:

- Valve body	Gun metal RG 5 W.No. 2.1086
- Stem	Stainless steel W.No. 1.4436
- O-ring	70 NBR
- Gasket	Reinz-AFM34
Nominal pressure	PN 16
Seating	Double seated
Flow characteristic	Linear
Leakage rate	$\leq 0.5\%$ of Kvs
Regulating capability	Kvs/Kvr > 25
Connection threads	ISO 7-1

Reverse acting (normally closed)
For cooling water and lubricants

PRESSURE/TEMPERATURE DIAGRAM

According to DIN 2401

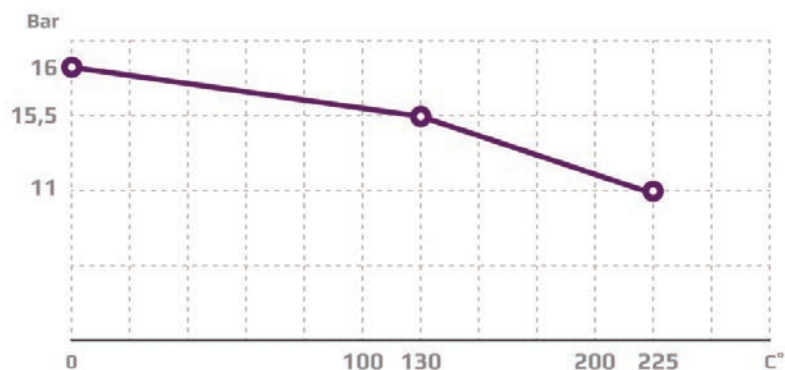

Subject to change without notice.

MOUNTING

The valve can be installed with vertical as well as horizontal spindles. For valve temperatures of max. 170 °C, the thermostat/ actuator can be fitted below or above the valve. For valve mounted with thermostats in media temperatures above 170 °C, a cooling unit has to be applied with connection downwards (please refer to data sheet for thermostat accessories). For electric actuators a high temperature adaptor must be used (please refer to data sheets for the electric actuators).



DIMENSION SKETCH

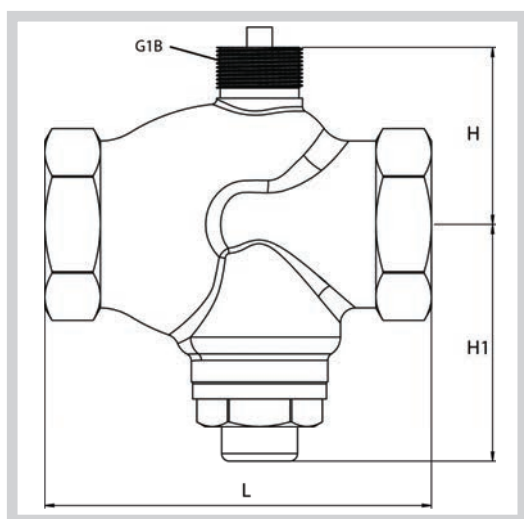

Type	L (mm)	H (mm)	H1 (mm)
40 L25R	129	65	90
50 L25R	153	70	94

SPECIFICATIONS

Type	Connection R _p	Opening dia. Mm	k _{vs} -value m ³ /h	Rated travel mm	Max. Δp _L bar	Actuator Force N	Corresp. p _{1max} bar	Weight kg
40 L25R	1 ½"	40	20.00	8	2.7	400	16.0	3.0
50 L25R	2"	50	30.00	9	1.8	400	16.0	4.0